

GO 580

IT MANUALE ISTRUZIONI

RIVETTATRICE OLEOPNEUMATICA CON TRATTENUTA DEL RIVETTO E RECUPERO DEL CHiodo TRANCIATO CON ARIA APERTA PER RIVETTI IN TUTTE LE LEGHE DAL Ø 2,4 AL Ø 4,8 SOLO PER ALLUMINIO Ø 6,0

EN INSTRUCTION MANUAL

HYDRO-PNEUMATIC TOOL WITH HOLDING OF THE RIVET AND NAIL RECOVERY WITH OPEN AIR FOR BLIND RIVETS IN ALL MATERIALS FROM Ø 2,4 TO 4,8 UP TO Ø 6,0 FOR ALUMINIUM ONLY

FR MANUEL D'INSTRUCTIONS

RIVETEUSE OLEOPNEUMATIQUE POUR LES RIVETS ALU/ACIER/INOX DE Ø 2,4 A Ø 4,8, Ø 6,0 ALUMINIUM SEULEMENT



INDICE

GARANZIA.....	4
DATI TECNICI	5
ACCESSORI IN DOTAZIONE.....	6
ACCESSORI A RICHIESTA.....	7
SICUREZZA.....	8
MESSA IN SERVIZIO.....	8
CAMBIO FORMATO E MANUTENZIONE.....	9
RABBOCCO OLIO.....	10
SMALTIMENTO	10
PARTI DI RICAMBIO.....	11

GARANZIA

Il periodo di garanzia è di 12 mesi dalla data riportata sulla relativa Fattura o Bolla di Consegna.

La Garanzia comprende esclusivamente le parti sostituite, con esclusione della mano d'opera.

Non sono compresi nella Garanzia, sia gli accessori standard sia i danni alla Macchina causati da:

- trasporto e/o movimentazione
- errori dell'Operatore
- mancata manutenzione prevista dal presente Manuale
- guasti e/o rotture non imputabili al malfunzionamento della stessa
- normale consumo delle parti soggette ad usura.

La manomissione/sostituzione non autorizzata di parti della macchina, l'uso di accessori, di utensili, di materiali di consumo diversi da quelli raccomandati dal costruttore potrebbero rappresentare un pericolo di infortunio e sollevano il costruttore dalla garanzia.

La Degometal si assume la responsabilità solo se la Macchina è difettosa all'origine e decade se l'utilizzatore non si adegua alle istruzioni fornite.

DATI TECNICI

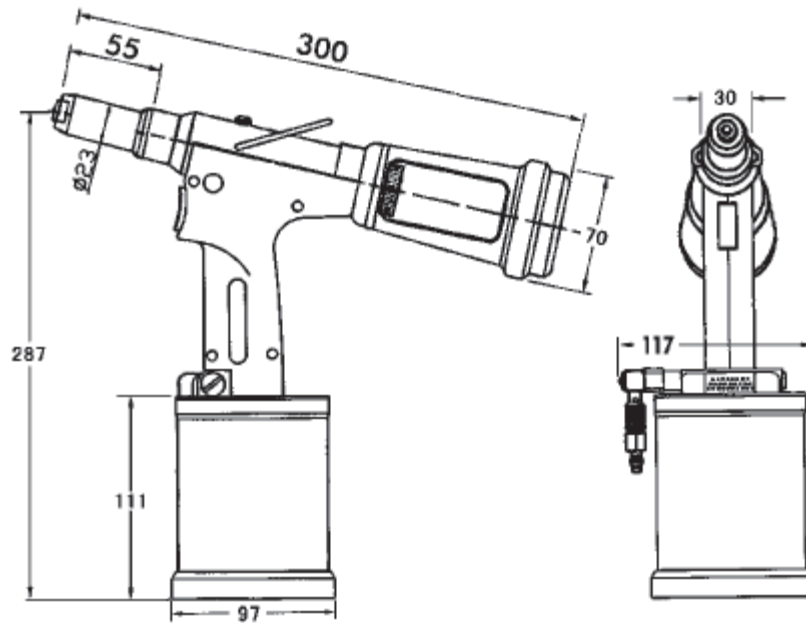

Pressione aria di esercizio	6 bar
Consumo aria per ciclo	4,35 litri
Corsa	20 mm
Forza di trazione	10.900 N
Peso	1,5 Kg
Vibrazioni	< 2,5 m/s ²
Rumorosità	78 dB (A)



Riportare in caso di assistenza la matricola incisa sulla fusione

ACCESSORI IN DOTAZIONE

FOTO	CODICE	QUANTITA'	ACCESSORI IN DOTAZIONE
	41990	1	Ugello Ø 2,4
	41991	1	Ugello Ø 3.2
	41992	1	Ugello Ø 4,0
	41691	1	Ugello Ø 4,8 (Già montato)
	40417	1	Ugello Ø 6.0 x alluminio
	25248	1	Ugello Ø 4,8 3/16 per rivetti Monriv
	12501	2	Morsetti (3 pezzi)
	41392	1	Apri morsetti
	41340	1	Molla apri morsetto
	41338	1	Cono porta morsetti
	-	1	Siringa per olio
	-	1	Olio
	-	1	Chiave a brugola esagonale 3 mm
	-	1	Chiave 10-12 mm
	-	2	Chiave 16-17 mm

La macchina è montata per rivetto Ø 4.8.



Valvola aperta
Valvola chiusa

ACCESSORI A RICHIESTA

Kit 503 - Prolunga 100 e 200 mm.

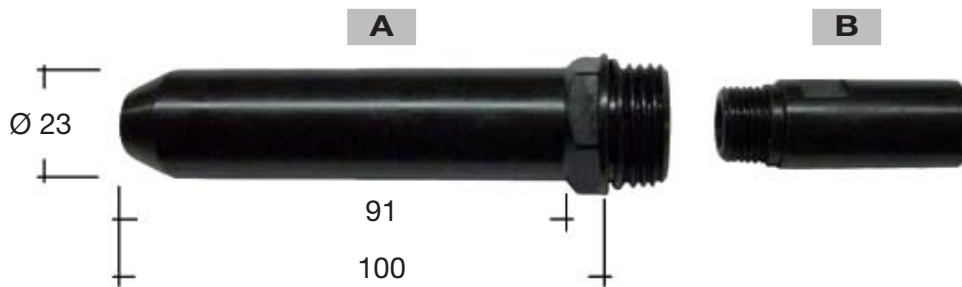

RIF.	CODICE	QUANTITÀ	DESCRIZIONE
A+B	42043	1	Kit 503 - Prolunga 100 mm

A	42024	1	Canotto prolungato 100 mm
B	41993	1	Adattatore x prolunga interna 100 mm



RIF.	CODICE	QUANTITÀ	DESCRIZIONE
A+B	42268	1	Kit 503 - Prolunga 200 mm

A	42267	1	Canotto prolungato 200 mm
B	42265	1	Adattatore x prolunga interna 200 mm

Per ottenere le prolunghie di 100 mm e di 200 mm occorre smontare i particolari esistenti e montare i nuovi corrispondenti (A e B) nella stessa sequenza.

SICUREZZA

- Non utilizzare questa rivettatrice se non per usi propri.
- Qualsiasi modifica eseguita dal cliente alla rivettatrice o a qualsiasi accessorio fornito dalla Degometal, sarà eseguita sotto la responsabilità assoluta del cliente. La Degometal declina ogni responsabilità.
- La rivettatrice deve essere sempre mantenuta in condizioni di sicurezza e deve essere controllata da personale addestrato e competente, ad intervalli regolari, secondo le procedure di manutenzione stabilite dalla Degometal.
- La rivettatrice dovrà essere sempre utilizzata secondo le norme relative "alla salute e sicurezza sul lavoro" (Direttiva 2006/42/CE). Qualsiasi problema o informazione relativi al funzionamento corretto della rivettatrice dovrà essere rivolto alla Degometal.
- Le precauzioni da osservare quando si utilizza questa rivettatrice devono essere spiegate dal cliente a tutti gli operatori. Staccare sempre l'alimentazione dell'aria dal punto di entrata dell'attrezzo prima di regolare, montare o smontare un canotto, cono o ugello.
- Non utilizzare l'utensile rivolgendolo verso altre persone.
- La pressione operativa non dovrà superare i 7 bar - 100 LBF/IN².
- Assicurarsi che gli scarichi d'aria non siano bloccati o coperti e che i tubi flessibili siano sempre in buone condizioni.
- Le operazioni di manutenzione, riparazione e pulizia della rivettatrice dovranno essere eseguite senza alimentazione dell'aria.
- Quando si usa la rivettatrice, indossare occhiali, visiere protettive e guanti.
- Usare esclusivamente ricambi originali. La Degometal declina ogni responsabilità per danni che si dovessero verificare per inadempienza dell'utilizzatore (direttiva CEE 85/734).
- In caso di esposizione quotidiana al rumore, superiore al limite di sicurezza di 85 dB (A), fare uso di adeguati mezzi di protezione individuali (cuffie, tappi antirumore).

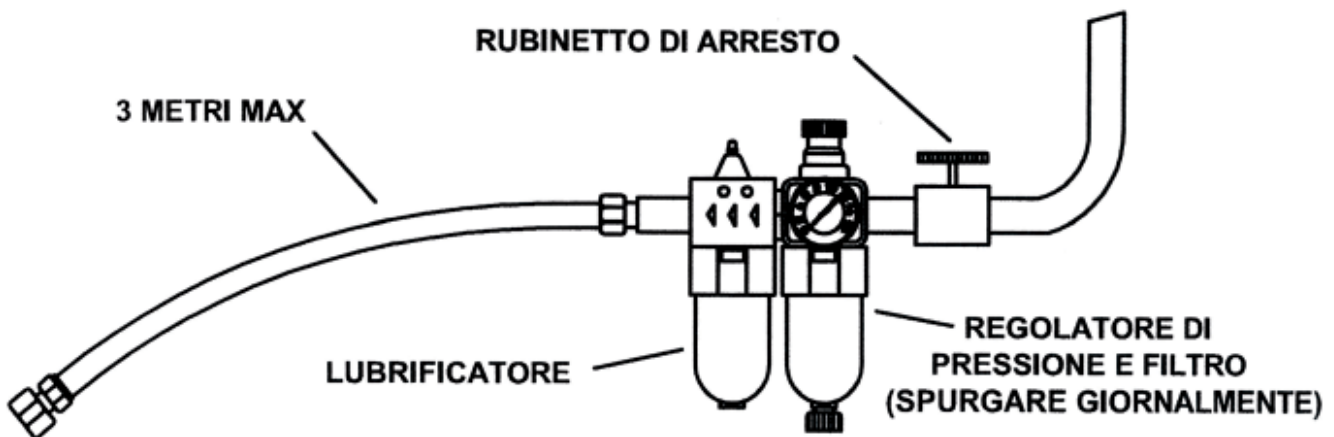

MESSA IN SERVIZIO

Alimentazione aria

Tutti gli utensili vengono fatti funzionare con aria compressa, ad una pressione di 6 bar.

Suggeriamo di utilizzare dei regolatori di pressione e dei sistemi di filtraggio automatico sulla rete principale di alimentazione aria.

Questi dovranno essere montati a 3 metri di distanza dall'attrezzo (vedere lo schema), per assicurare una pressione ottimale nell'utensile e la durata massima dell'attrezzo con un minimo di manutenzione. I tubi flessibili per l'aria compressa in entrata devono essere in grado di sostenere una pressione di 10 bar e dovranno essere resistenti all'olio, rivestiti internamente di materiale resistente alle abrasioni e protetti qualora le condizioni di lavoro possano danneggiarli.

Tutti i tubi flessibili per l'aria compressa devono avere un diametro di passaggio minimo di 6,4 mm o 1/4 di pollice.

Il regolatore di pressione deve essere impostato a 6,5 bar in considerazione della caduta di pressione.



Pomolo regolazione aspirazione: per regolare l'aspirazione ruotare la manopola di 1/4 di giro.

CAMBIO FORMATO E MANUTENZIONE

Cambio formato

Per il cambio dell'ugello, servirsi della chiave da 12 mm in dotazione.

Manutenzione

Controllare che i morsetti non slittino sul chiodo.

Le cause dello slittamento possono essere: morsetti con deposito di impurità sui denti o usurati.

Nel primo caso, si dovrà procedere alla pulizia ed alla successiva lubrificazione; nel secondo alla loro sostituzione.

Innanzitutto, togliere aria alla rivettatrice, quindi smontare con la chiave da 25 mm il canotto; successivamente con la chiave da 16 mm e 17 mm togliere il cono porta morsetti e procedere o alla pulizia o alla sostituzione dei morsetti.

Controllare la pressione, che non deve superare i 7 bar.

Controllare se ci sono perdite di aria o olio.

Controllare la corsa della rivettatrice: se non dovesse fare la corsa stabilita, procedere al rabbocco dell'olio.



Rabbocco olio



RABBOCCO OLIO

Il rabbocco dell'olio è necessario quando si avverte una diminuzione della corsa della rivettatrice. Procedere nel seguente modo:

- Togliere aria all'utensile e tenerlo in posizione verticale.
- Svitare la vite dell'olio con la chiave a brugola da 3 mm, avvitare la siringa in dotazione iniettandolo finchè non fa resistenza, usare olio viscosità 32°.
- Togliere la siringa; avvitare la vite con la guarnizione e stringere.
- Inserire aria senza spingere il grilletto.
- Svitare la vite con lentezza in modo che fuoriesca l'olio eccessivo (spurgo).
- Avvitare vite stringendola.
- Attrezzo pronto.
- N.B. In caso di incertezza controllare la corsa che non deve essere inferiore ai dati tecnici.

N.B. Nell'operazione di rabbocco, proteggersi con guanti e non disperdere nell'ambiente l'eventuale olio residuo. In caso di contatto, lavarsi con sapone.

SMALTIMENTO

Per lo smaltimento della rivettatrice, attenersi alle leggi nazionali in materia di smaltimento rifiuti. Smontare la rivettatrice, suddividendo i vari componenti (alluminio, acciaio, plastica etc.) e procedere alla rottamazione, in conformità a quanto prescritto dalla normativa nazionale.

PARTI DI RICAMBIO

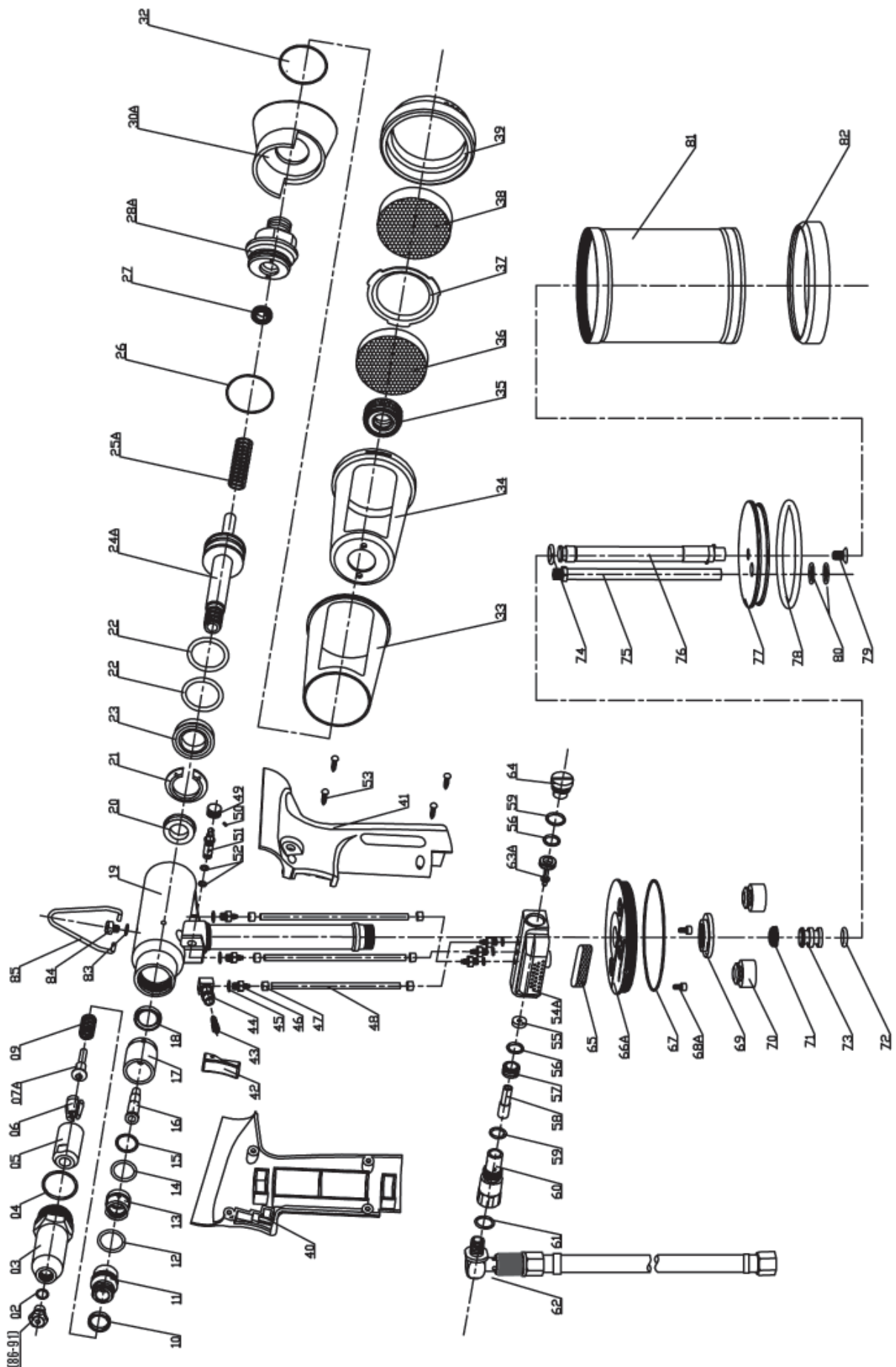

RIF.	CODICE	QUANTITA'	DESCRIZIONE
2	41692	1	O-Ring
3	41337	1	Canotto
4	41721	1	O-ring
5	41338	1	Cono morsetti
6	12501	3	Morsetti
7A	41392	1	Apri morsetti
9	41340	1	Molla di richiamo morsetti
10	41722	1	O-ring
11	42455	1	Raccordo
12	41726	1	O-ring
13	43408	1	Guarnizione
14	41727	1	O-ring
15	41728	1	O-ring
16	42397	1	Boccola d'aspirazione
17	43409	1	Distanziale
18	41341	1	Guarnizione
19	43410	1	Cilindro testa
20	41432	1	O-ring
21	41347	1	Anello anti estrusione
22	41348	2	O-ring
23	41349	1	Anello teflon
24A	43411	1	Pistone
25A	43983	1	Molla
26	42250	1	O-ring
27	41350	1	Guarnizione
28A	43984	1	Tappo chiusura
30A	43985	1	Attacco contenitore
32	42253	1	O-ring
33	41359	1	Contenitore di chiodi
34	41360	1	Corpo contenitore
35	43378	1	Ghiera
36	41729	1	Silenziatore
37	41733	1	Chiusura silenziatore
38	41730	1	Silenziatore
39	41734	1	Tappo silenziatore
40	41443	1	Impugnatura sinistra
41	41444	1	Impugnatura destra
42	41449	1	Grilletto
43	43382	1	Pulsante grilletto
44	43383	1	Valvola
45	43384	6	O-ring
46	43385	6	Raccordo
47	43386	6	Distanziale
48	43387	3	Tube aria
49	43171	1	Ghiera regolazione
50	43172	1	Vite
51	43415	1	Valvola
52	43416	2	O-ring
53	41450	4	Vite
54A	43152	1	Corpo valvola aria
55	41376	1	Anello valvola aria
56	41377	2	O-ring

57	41378	1	Base valvola aria
58	43115	1	Raccordo
59	42254	2	O-ring
60	43389	1	Raccordo
61	42255	1	O-ring
62	42940	1	Raccordo girevole
63A	41379	1	Tirante valvola
64	43052	1	Vite
65	41731	1	Silenziatore
66A	43393	1	Fondello cilindro
67	41380	1	O-ring
68A	43400	2	Vite
69	43402	1	Ghiera
70	41810	2	Ammortizzatore
71	41381	1	O-ring
72	41382	1	Rondella teflon
73	43404	1	Pistone
74	42257	1	Rondella pistone
75	43418	1	Tube
76	43444	1	Stelo
77	43406	1	Pistone pneumatico
78	41385	1	O-ring
79	42654	1	Vite
80	41655	2	O-ring
81	43425	1	Cilindro
82	43173	1	Fondello di protezione
83	42396	1	Guarnizione
84	43174	1	Tappo olio
85	43175	1	Gancio
86	41990	1	Ugello Ø 2,4
87	41991	1	Ugello Ø 3,0 - 3,2
88	41992	1	Ugello Ø 4,0
89	40417	1	Ugello Ø 6,0
90	41691	1	Ugello Ø 4,8
91	25248	1	Ugello Ø 4,8 3/16 per rivetti Monriv

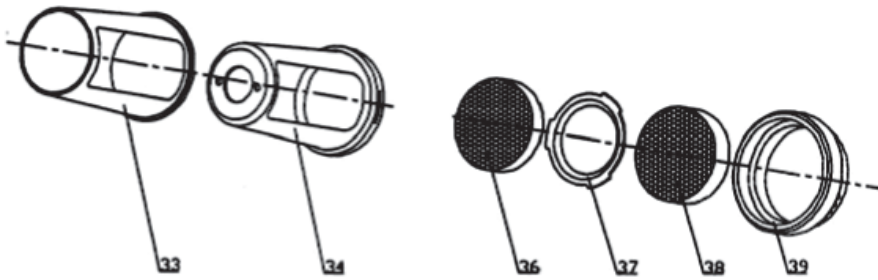
Kit 503 - Kit contenitore chiodi

RIF.	CODICE	QUANTITÀ	DESCRIZIONE
	42042	1	Kit contenitore chiodi

32	42253	1	O-ring
33	41359	1	Contenitore chiodi
34	41360	1	Corpo contenitore
36	41729	1	Silenziatore
37	41733	1	Chiusura silenziatore
38	41730	1	Silenziatore
39	41734	1	Tappo silenziatore

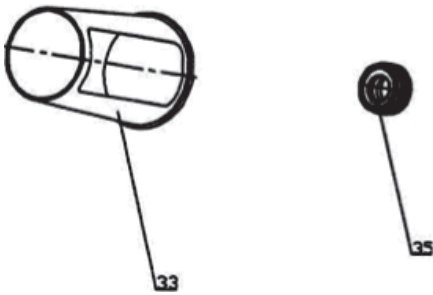

33	41359	1	Contenitore chiodi
35	43378	1	Ghiera

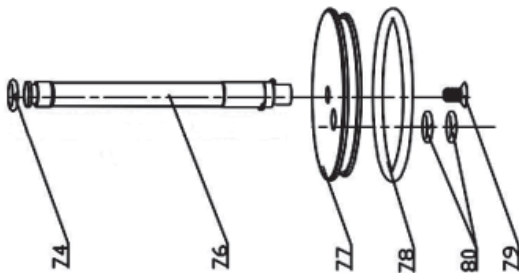
Kit 503 - Kit pistone pneumatico completo

RIF.	CODICE	QUANTITÀ	DESCRIZIONE
-	43424	1	Kit pistone pneumatico completo

74	42257	1	Rondella pistone
76	43444	1	Stelo
77	43406	1	Pistone pneumatico
78	41385	1	O-ring
79	42654	1	Vite
80	42655	2	O-ring

INDEX

WARRANTY.....	16
TECHNICAL DATA.....	17
ACCESSORIES SUPPLIED	18
ACCESSORIES ON REQUEST.....	19
SAFETY MEASURES.....	20
OPERATING INSTRUCTIONS	20
SIZE CHANGING AND MAINTENANCE.....	21
OIL TOPPING UP	22
ELIMINATION OF THE TOOL	22
LIST OF SPARE PARTS.....	23

WARRANTY

The warranty has a validity of 12 months, as of the date indicated on the invoice.

The warranty only covers replaced parts; labour is not included.

The following are not covered by warranty: standard accessories and tool damages caused by:

- transport and/or handling
- user's mistakes
- failed servicing/maintenance, as indicated in this manual
- faults and/or breakages that are not attributable to tool anomalies
- normal consumption of consumables.

The warranty is invalidated both in case of unauthorised tampering/replacements of tool components and in case of use of accessories, tools or consumables different to those recommended by the manufacturer, which could even cause injuries to the tool's user.

Degometal assumes responsibilities only if the tool is originally defective, but declines all forms of responsibility if the user fails to follow the given instructions.

TECHNICAL DATA

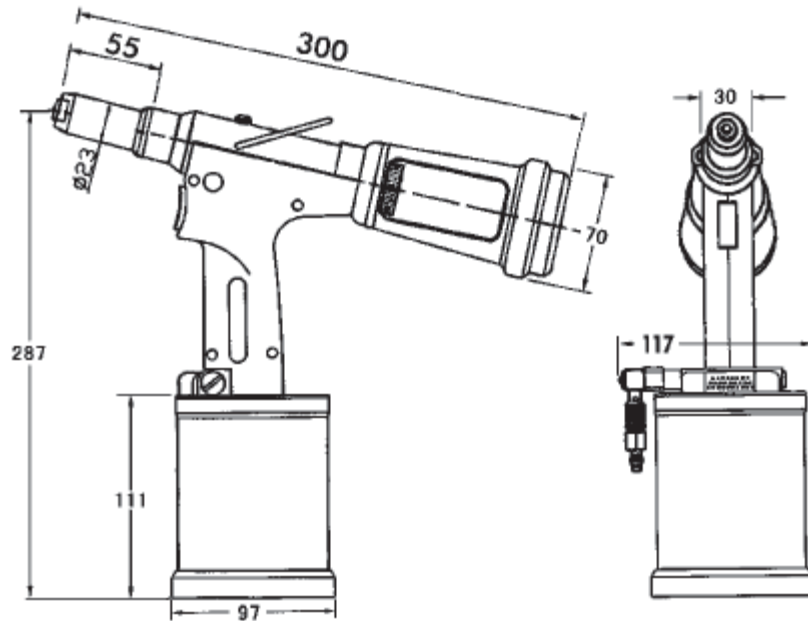

Air pressure	6 bar
Air consumption per stroke	4,35 litri
Stroke	20 mm
Force	10.900 N
Weight	1,5 Kg
Vibration	< 2,5 m/s ²
Noise level	78 dB (A)



In case of assistance please specify the serial number on the external case

ACCESSORIES SUPPLIED

PHOTO	CODE	QUANTITY	ACCESSORIES SUPPLIED
	41990	1	Nosepiece Ø 2,4
	41991	1	Nosepiece Ø 3,2
	41992	1	Nosepiece Ø 4,0
	41691	1	Nosepiece Ø 4.8 (on head)
	40417	1	Nosepiece Ø 6,0 for aluminium
	25248	1	Nosepiece Ø 4,8 3/16 for Monriv rivet
	12501	2	Jaws (3 pcs)
	41392	1	Jaws opener
	41340	1	Jaws return spring
	41338	1	Cone holding jaws
	-	1	Oil syringe
	-	1	Oil
	-	1	Hexagonal allen wrench 3 mm
	-	1	10-12 mm wrench
	-	2	16-17 mm wrench

The tools is prepared for Ø 4.8 blind rivet.



Open valve
Close valve

ACCESSORIES ON REQUEST

Kit 503 - Extension 100 and 200 mm.

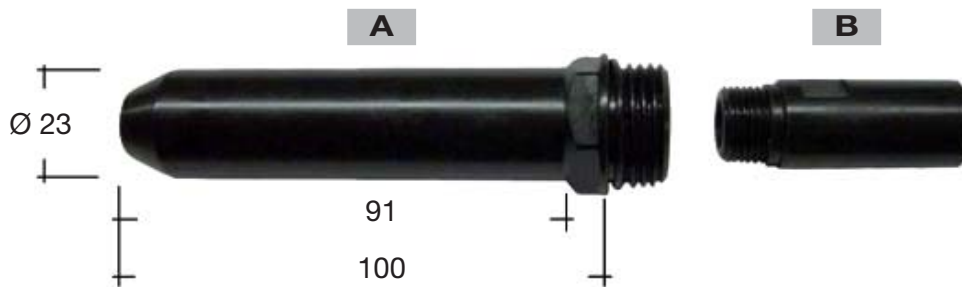

REF.	CODE	QUANTITY	DESCRIPTION
A+B	42043	1	Kit 503 - Extension 100 mm

A	42024	1	Extended sleeve 100 mm
B	41993	1	Adaptor x internal extension x 100 mm



REF.	CODE	QUANTITY	DESCRIPTION
A+B	42268	1	Kit 503 - Extension 200 mm

A	42267	1	Extended sleeve 200 mm
B	42265	1	Adaptor x internal extension x 200 mm

To get the 100 mm and the 200 mm extensions you need to disassemble the parts and assemble the new correspondent ones (A and B) in the same sequence.

SAFETY MEASURES

- Use the riveting tool properly and for the purposes for which it has been manufactured.
- Any kind of modification made on the riveting tool and its equipment by the customer itself, will be done under the fully responsibility of the customer. In this case, Degometal declines any responsibility.
- The riveting tool must be always kept in safety conditions and must be revised at regular intervals by expert and authorized workers, following the maintenance producers of Degometal.
- The riveting tool will always be used following the EC normative "on health and safety measures on job" (Directive 2006/42/EC). Any problem or information regarding the correct operating of the tool, will have to be returned to Degometal.
- The safety measures to be observed during the use of the riveting tool, must be explained from the customer to all users. Always detach the air feeding from the take-off point of the tool before regulating, repairing and cleaning operations.
- Don't use the tool if it is turned towards other persons.
- Operating pressure have not to exceed 7 bar - 100 LBF/IN².
- Make sure that the air discharges are not blocked or covered and the feeding hoses are always in good working conditions.
- The operations of maintenance, repairing and cleaning must be done when the tool is not fed.
- When using the riveting tool, wear protective glasses or visors and gloves.
- Use only original spare parts for repairing and maintenance. Degometal declines any responsibility for any kind of damages caused by not observing the above and following instructions (directive CEE 85/734).
- If the noise level is over the safety limit of 85 dB (A), use the proper hearing protections (antinoise headset etc.).

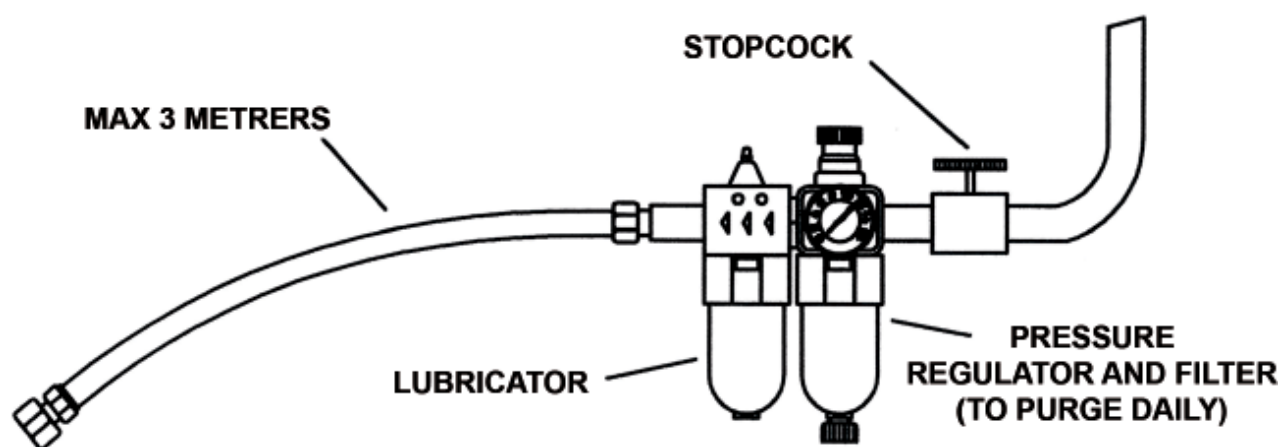

OPERATING INSTRUCTIONS

Air feed

All the tools works with compressed air, with a pressure of 6 bar.

We suggest to use regulators of pressure and automatic filtering systems on the main net of feeding air. These will have to stay to 3 meters of distance from the tool (see the drawing), in order to assure an optimal pressure in the tool and its maximum duration-life with a minimum maintenance.

The flexible tubes for the air compressed in entrance must be in a position to supporting a pressure of 10 bars and will have to be resistant to the oil, covered of a material resistant to the abrasions and protected in case bad job conditions could damage them.

All the flexible tubes for the compressed air must have a diameter of minimum passage of 6,4 mm or 1/4 of inch.

The pressure regulator must be set up to 6,5 bars in consideration of the pressure fall.



Knob for suction adjusting: to adjust the air suction rotate the knob

SIZE CHANGING AND MAINTENANCE

Size changing

For changing the size of nosepiece, use the 12 mm spanner (equipped).

Maintenance

Check the grip of the jaws on the rivet's nail.

If it is anomalous, this is due to a problem on the jaws: dirty jaws or wear of the jaws.

In the first case, proceed with cleaning and oiling the jaws; in the second case, it is necessary to substitute the jaws with new ones.

In order to do these operations, first of all, disconnect the air feeding; then remove the head carrying nosepiece with a 25 mm spanner.

Then with 16 mm and 17 mm spanner keep off the cone holding jaws and proceed with cleaning or changing the jaws.

Check the air pressure, which don't have to exceed 7 bar.

Check eventual losses of oil or air.

Check the stroke of the riveting tool. If it is anomalous, proceed with topping up new oil.



Oil topping up



OIL TOPPING UP

The topping up of the oil is necessary when occurs a power loss of the riveting tool or after a long period of use.

Proceed as per the following instructions:

- Disconnect the air supply from the tool and keep the tool in a vertical position.
- Remove oil screw using a 3 mm allen wrench, screw the oil syringe (equipped) until it makes no resistance, use oil viscosity 32°.
- Remove the syringe, then screw the oil screw with its o-ring and tighten.
- Place air without pressing the trigger.
- Unscrew the screw slowly so that the exceeding oil comes out (bleeding).
- Tighten screw.
- The tool is ready.
- N.B. In case of doubt check stroke, whose regulation should never be lower than the technical data.

N.B. During the operation, wear protective gloves and don't waste oil in the environment. In case of contact of oil with skin, wash carefully the part with water and soap.

ELIMINATION OF THE TOOL

For the elimination of the tool, make reference to your national laws for safety and environments care. Disassemble the tool, dividing its components by materials (aluminium, steel, plastic etc.) then proceed to scrap in compliance to the current law.

LIST OF SPARE PARTS

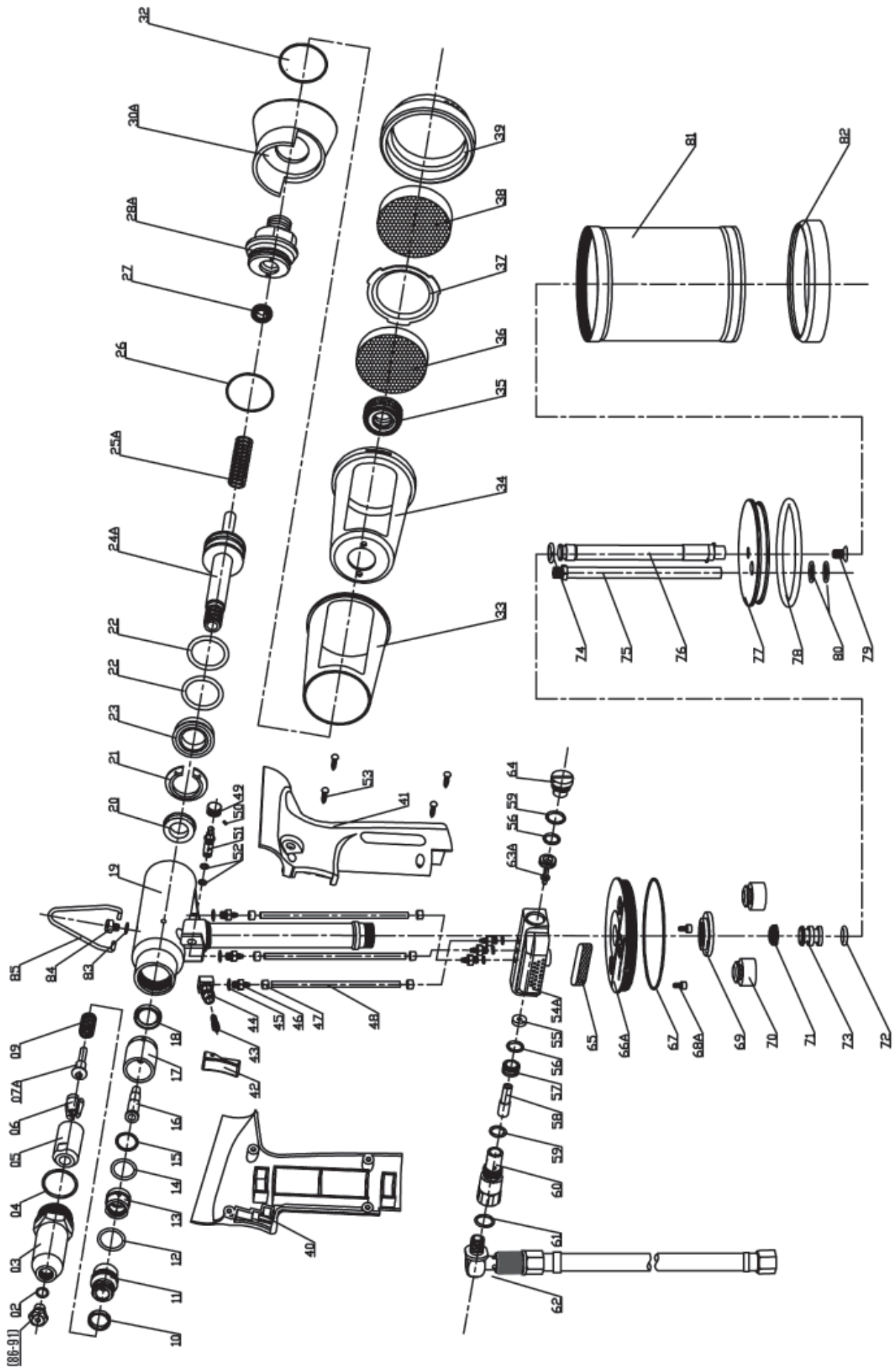

REF.	CODE	QUANTITY	DESCRIPTION
2	41692	1	O-Ring
3	41337	1	Head carryng nosepiece
4	41721	1	O-ring
5	41338	1	Cone holding jaws
6	12501	3	Jaws
7A	41392	1	Jaws opener
9	41340	1	Jaws return spring
10	41722	1	O-ring
11	42455	1	Connector
12	41726	1	O-ring
13	43408	1	Gasket
14	41727	1	O-ring
15	41728	1	O-ring
16	42397	1	Intake mandrel
17	43409	1	Spacer
18	41341	1	Gasket
19	43410	1	Head cylinder
20	41432	1	O-ring
21	41347	1	Anti-extrusion ring
22	41348	2	O-ring
23	41349	1	Teflon ring
24A	43411	1	Piston
25A	43983	1	Spring
26	42250	1	O-ring
27	41350	1	Gasket
28A	43984	1	End plug
30A	43985	1	Stem adaptor
32	42253	1	O-ring
33	41359	1	Nail collector
34	41360	1	Nail collector body
35	43378	1	Connector
36	41729	1	Silcencer
37	41733	1	End collector body
38	41730	1	Silcencer
39	41734	1	End Silcencer
40	41443	1	Left handle
41	41444	1	Right handle
42	41449	1	Trigger
43	43382	1	Trigger leve
44	43383	1	Valve
45	43384	6	O-ring
46	43385	6	Air valve
47	43386	6	Spacer
48	43387	3	Air tube
49	43171	1	Ring nut
50	43172	1	Screw
51	43415	1	Valve
52	43416	2	O-ring
53	41450	4	Screw
54A	43152	1	Air valve body
55	41376	1	Air valve ring
56	41377	2	O-ring

57	41378	1	Air valve base
58	43115	1	Connector
59	42254	2	O-ring
60	43389	1	Connector
61	42255	1	O-ring
62	42940	1	Rotating valve
63A	41379	1	Valved rod
64	43052	1	Screw
65	41731	1	Silcencer
66A	43393	1	Cylinder bottom
67	41380	1	O-ring
68A	43400	2	Screw
69	43402	1	Pin
70	41810	2	Buffer
71	41381	1	O-ring
72	41382	1	Washer teflon
73	43404	1	Piston
74	42257	1	Washer Piston
75	43418	1	Tube
76	43444	1	Stem
77	43406	1	Pneumatic piston
78	41385	1	O-ring
79	42654	1	Screw
80	41655	2	O-ring
81	43425	1	Cylinder
82	43173	1	Protection bottom
83	42396	1	Gasket
84	43174	1	Screw
85	43175	1	Hook
86	41990	1	Nosepiece Ø 2,4
87	41991	1	Nosepiece Ø 3,0 - 3,2
88	41992	1	Nosepiece Ø 4,0
89	40417	1	Nosepiece Ø 6,0
90	41691	1	Nosepiece Ø 4,8
91	25248	1	Nosepiece Ø 4,8 3/16 for Monriv rivets

Kit 503 - Kit nail collector

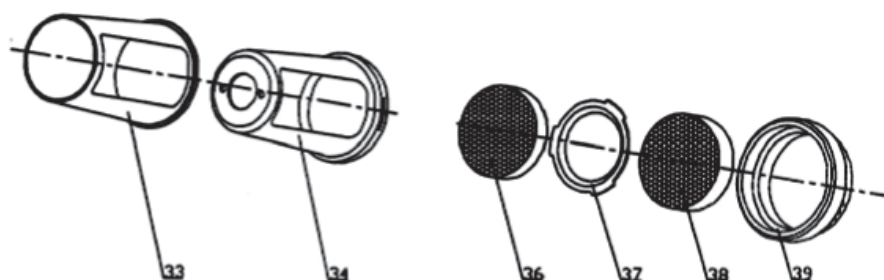

REF.	CODE	QUANTITY	DESCRIPTION
	42042	1	Kit nail collector

32	42253	1	O-ring
33	41359	1	Nail collector
34	41360	1	Nail collector body
36	41729	1	Silencer
37	41733	1	End collector body
38	41730	1	Silencer
39	41734	1	End silencer

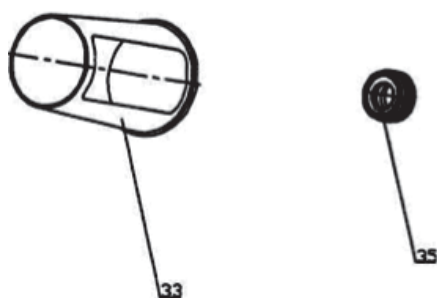

33	41359	1	Nail collector
35	43378	1	Connector

Kit 503 - Kit pneumatic piston

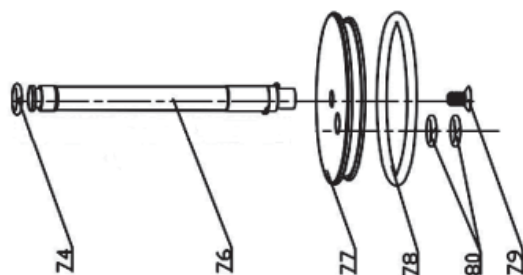

REF.	CODE	QUANTITY	DESCRIPTION
-	43424	1	Kit pneumatic piston

74	42257	1	Piston ring
76	43444	1	Stem
77	43406	1	Pneumatic piston
78	41385	1	O-ring
79	42654	1	Screw
80	42655	2	O-ring

INDICE

GARANTIE ET ASSISTANCE TECHNIQUE	28
CARACTÉRISTIQUES TECHNIQUES.....	29
ACCESSOIRES FOURNIS.....	30
ACCESSOIRES EN OPTION	31
MESURES DE SECURITE	32
NOTICE D'UTILISATION.....	32
CHANGEMENT DE DIMENSION ET MAINTENANCE.....	33
REPLISSAGE HUILE	34
DEMOLITION DE L'OUTIL.....	34
PIÈCES DÉTACHÉES	35

GARANTIE ET ASSISTANCE TECHNIQUE

Les riveteuses Degometal sont couvertes par une garantie de 12 mois, à compter de la date de livraison indiquée sur la facture ou sur le bon de livraison.

La garantie est accordée à l'utilisateur/acheteur quand la machine est achetée par l'intermédiaire d'un revendeur agréé et uniquement à condition qu'elle soit utilisée pour l'usage prévu. La garantie n'est pas applicable si la machine n'est pas utilisée ni soumise aux interventions d'entretien prévues dans le manuel d'utilisation et d'entretien.

En cas de défaut ou autre anomalie, Degometal s'engage uniquement à réparer ou changer, selon son choix, les pièces défectueuses.

CARACTÉRISTIQUES TECHNIQUES

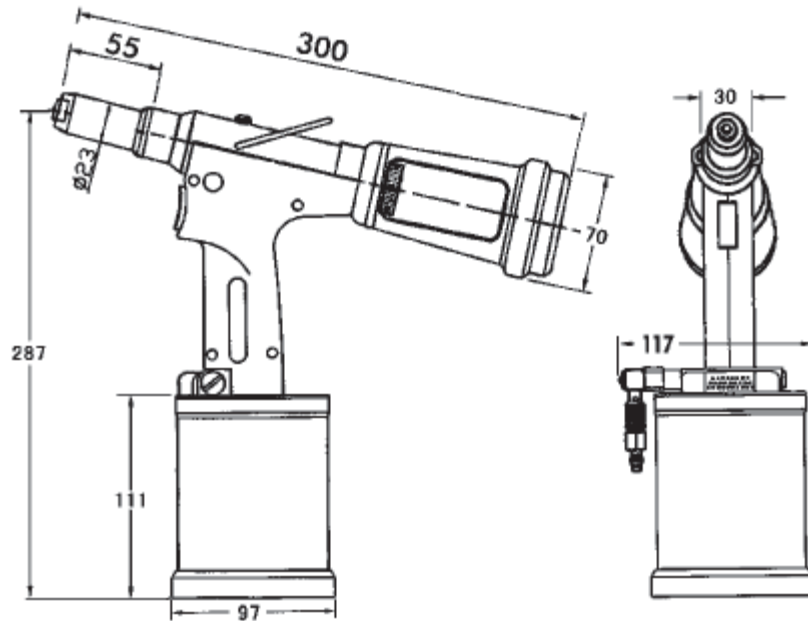

Pression air	6 bar
Consommation air rivet	4,35 litre
Course	20 mm
Puissance	10.900 N
Poids	1,5 Kg
Vibrations	< 2,5 m/s ²
Niveau sonore	78 dB (A)



En cas d'assistance
spécifiez le numéro de
série écrit sur l'outil

ACCESSOIRES FOURNIS

PHOTO	CODE	QUANTITE'	ACCESSOIRES FOURNIS
	41990	1	Embout Ø 2,4
	41991	1	Embout Ø 3,2
	41992	1	Embout Ø 4,0
	41691	1	Embout Ø 4,8 (Déjà monté)
	40417	1	Embout Ø 6,0
	25248	1	Embout Ø 4,8 3/16 pour rivets Monriv
	12501	2	Mâchoires (3 pcs)
	41392	1	Ouvre-étaux
	41340	1	Ressort retour
	41338	1	Cone porte étaux
	-	1	Seringue pour huile
	-	1	Huile
	-	1	Hexagonal clé 3 mm
	-	1	Clé 10-12 mm
	-	2	Clé 16-17 mm

L'outil est équipé pour le rivet Ø 4.8.

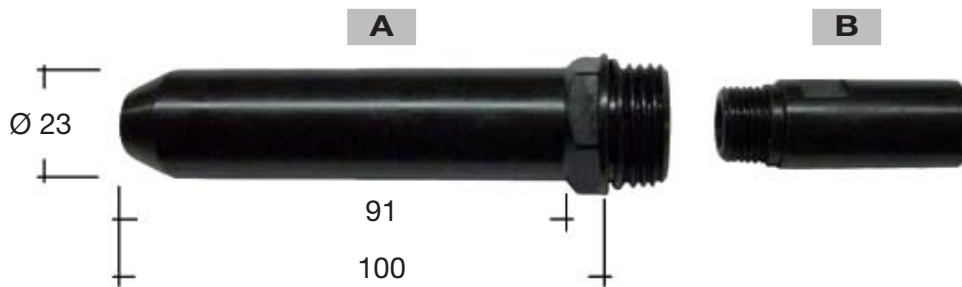

Soupape ouverte
 Soupape fermée

ACCESSOIRES EN OPTION
Kit 503 - Extension 100 and 200 mm.

REF.	CODE	QUANTITE'	DESCRIPTION
A+B	42043	1	Kit 503 - Prolonge 100 mm

A	42024	1	Tube prolongé 100 mm
B	41993	1	Adaptateur x prolonge interne x 100 mm



REF.	CODE	QUANTITE'	DESCRIPTION
A+B	42268	1	Kit 503 - Prolonge 200 mm

A	42267	1	Tube prolongé 200 mm
B	42265	1	Adaptateur x prolonge interne x 200 mm

Pour obtenir des prolongements de 100 mm et 200 mm on doit démonter les pièces existantes et monter les nouvelles correspondantes (A et B) dans la même séquence.

MESURES DE SECURITE

- Utiliser l'outil correctement et pour les buts pour lesquels il a été fabriqué.
- Toute modification faite sur l'outil et son équipement par le client lui-même, sera fait entièrement sous la responsabilité du client. Dans ce cas-ci, Degometal refuse toute responsabilité.
- L'outil doit être toujours maintenu en sécurité et doit être mis à jour régulièrement par l'expert et les ouvriers autorisés, après les procédures d'entretien de Degometal.
- L'outil sera toujours utilisé suivant la norme EC "sur des mesures de santé et sécurité sur le travail" (Directive 2006/42/EC). Tout problème ou information concernant l'utilisation correcte de l'outil, devra être indiqué à Degometal.
- Les mesures de sécurité observées pendant l'utilisation de l'outil, doivent être expliquées par le client à tous les utilisateurs. Détacher toujours la prise d'air de l'outil avant le réglage, le montage ou le démontage d'un canot, d'un cône ou d'une buse.
- Ne pas utiliser l'outil s'il est tourné vers d'autres personnes.
- La pression de fonctionnement ne doit pas dépasser 7 bar - 100 LBF/IN².
- S'assurer que les rejets d'air ne sont pas bloqués ni couverts et les tuyaux d'alimentation sont toujours en bon état.
- Les opérations d'entretien, réparation et nettoyage doivent être faites quand l'outil est hors alimentation.
- Quand vous utilisez l'outil, porter des lunettes ou des visières et des gants protecteurs.
- Utilisez seulement les pièces détachées originales pour la réparation et l'entretien. Degometal decline toute responsabilité concernant des dommages provoqués en n'observant pas les instructions ci-dessus et suivantes (Directive CEE 85/734).
- Si le niveau de bruit est au-dessus de la limite de sûreté du dB 85 (A), utiliser les protections d'audition appropriées (casque anti-bruit etc.)

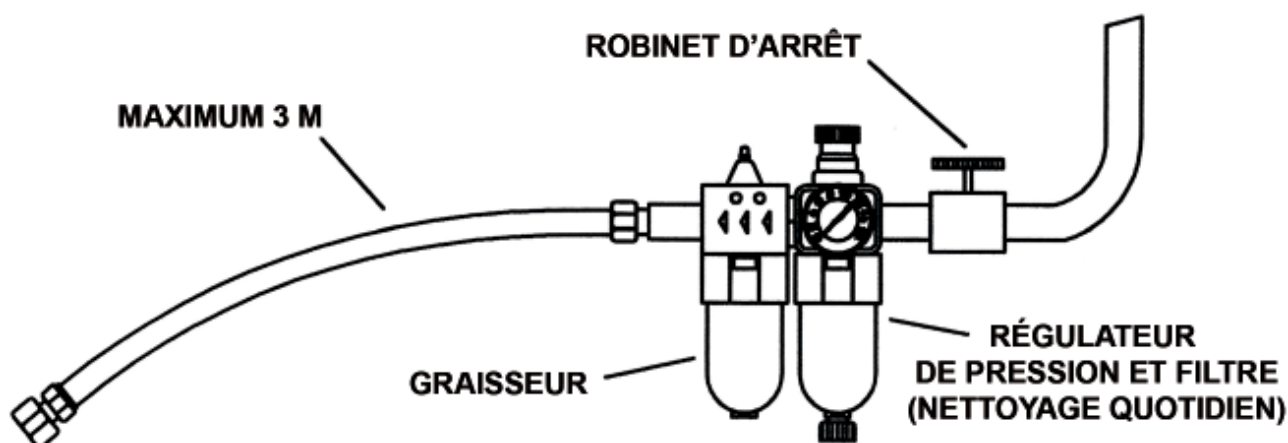

NOTICE D'UTILISATION

Alimentation en air

Tous les outils fonctionnent à air comprimé, avec la pression de 6 bar.

Nous conseillons d'utiliser des régulateurs de pression et des systèmes de filtrage automatiques sur le filet principal d'alimentation en air.

Ceux-ci devront rester à 3 mètres de l'outil (voir le schéma), afin d'assurer une pression optimale dans l'outil et une durée de vie maximum avec un entretien minimum.

Les tubes flexibles pour l'air comprimé en entrée doivent supporter une pression de 10 bar et devront être résistants à l'huile, couverts d'un matériel résistant aux abrasions et protégé de tout endommagement. Tous les tubes flexibles pour l'air comprimé doivent avoir un diamètre de passage de minimum 6.4 mm ou $\frac{1}{4}$ de pouce.

Le régulateur de pression doit être installé à 6.5 bar en tenant compte de la chute de pression.



Bouton pour le réglage de l'aspiration: pour la régulation de l'aspiration tourner le bouton

CHANGEMENT DE DIMENSION ET MAINTENANCE

Changement de dimension

Pour changer la buse, utiliser la clé de 12 mm.

Entretien

Contrôler que les mâchoires ne glissent pas sur le clou.

La cause du glissement peut être: mâchoires avec des impuretés sur les dents ou usées.

Dans le premier cas, on devra les nettoyer et les lubrifier; dans le second cas, on devra les changer.

Avant tout, enlever l'air de la riveteuse, donc démonter avec la clé de 25 mm le canot; successivement, avec la clé de 16 mm et 17 mm enlever la cône porte-mors et nettoyer ou changer les mâchoires.

Vérifier la pression d'air, qui ne doit pas dépasser 7 bars.

Vérifier les pertes d'huile ou d'air.

Vérifier l'indicateur du levier d'huile. Si l'indication n'est pas correcte, remplir avec une huile neuve.

**Remplissage huile****REPLISSAGE HUILE**

Le remplissage huile est nécessaire quand se produit une perte de puissance de la riveteuse. Procéder selon les instructions suivantes:

- Déconnecter l'arrivée en air de l'outil et maintenir l'outil dans une position verticale.
 - Dévisser la vis d'huile en utilisant une clé de 3 mm, visser la seringue d'huile (équipée) en introduisant l'huile hydraulique 32°, jusqu'à ce qu'il n'y ait plus de résistance.
 - Enlever la seringue, puis visser la vis d'huile avec son joint torique et serrer.
 - Connecter l'approvisionnement d'air de l'outil sans actionner le levier.
 - Dévisser lentement la vis pour faire sortir l'huile en excès (purge).
 - Visser la vis en la serrant.
 - Outil prêt.
 - N.B. En cas de doute contrôler la course de l'outil qui ne doit pas être inférieure aux données techniques.
- N.B. Pendant cette opération, porter des gants protecteurs et ne pas jeter l'huile dans l'environnement. En cas de contact d'huile avec la peau, laver soigneusement avec eau et savon.

DEMOLITION DE L'OUTIL

Pour l'élimination de l'outil, se conformer aux lois nationales sur le recyclage. Démontez l'outil, séparez ses composants par matériaux (aluminium, acier, plastique etc.) et déchets en conformité à la norme nationale.

PIÈCES DÉTACHÉES

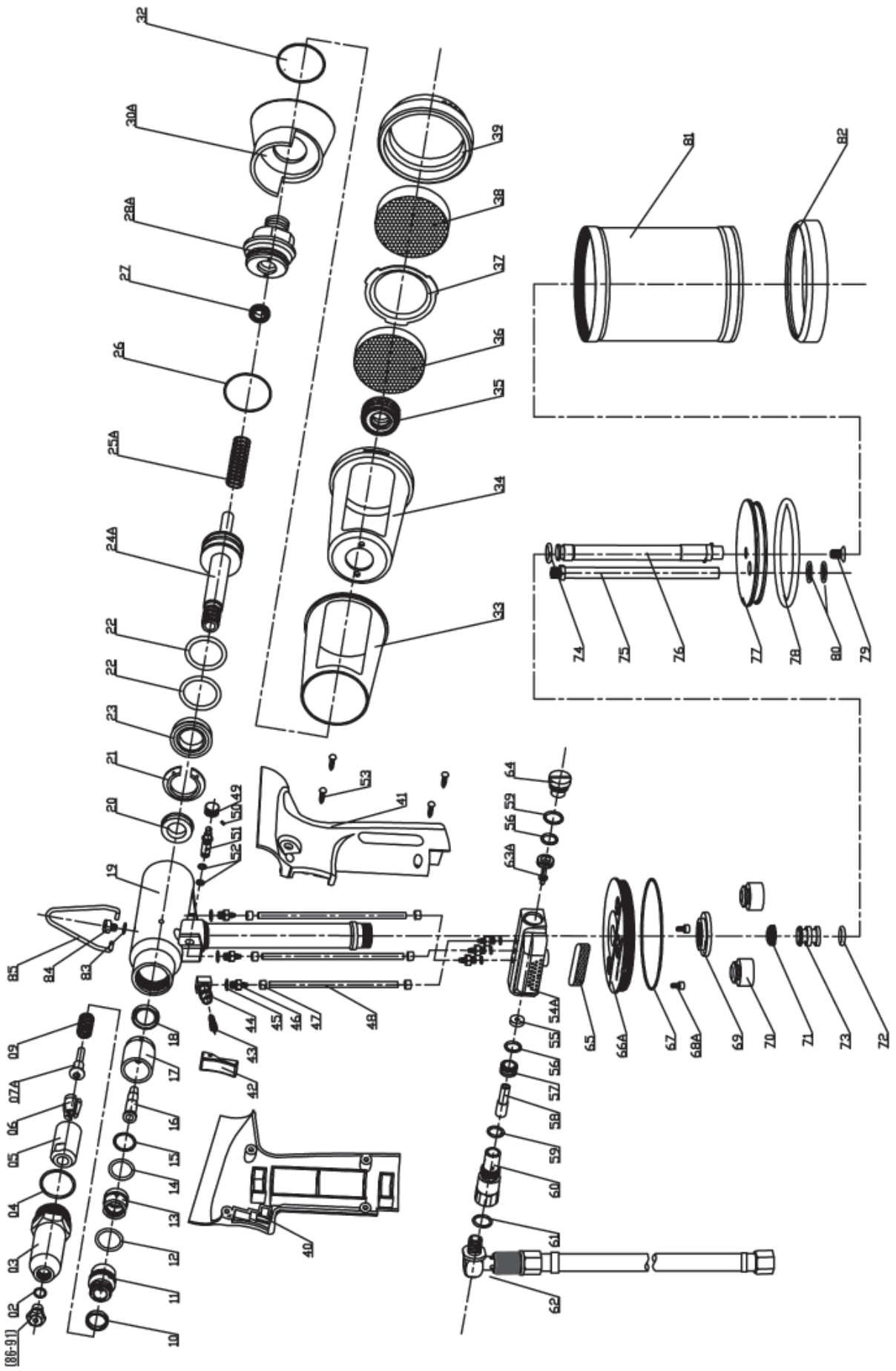

REF.	CODE	QUANTITE'	DESCRIPTION
2	41692	1	O-Ring
3	41337	1	Tête porte embout
4	41721	1	O-ring
5	41338	1	Cone porte étaux
6	12501	3	Mâchoires
7A	41392	1	Ouvre-étaux
9	41340	1	Ressort retour
10	41722	1	O-ring
11	42455	1	Raccord
12	41726	1	O-ring
13	43408	1	Garniture
14	41727	1	O-ring
15	41728	1	O-ring
16	42397	1	Tube d'aspiration
17	43409	1	Entretoise
18	41341	1	Garniture
19	43410	1	Cylindre tete
20	41432	1	O-ring
21	41347	1	Bauge anti-extrusion
22	41348	2	O-ring
23	41349	1	Bauge teflon
24A	43411	1	Piston
25A	43983	1	Retour
26	42250	1	O-ring
27	41350	1	Garniture
28A	43984	1	Bouchon
30A	43985	1	Attache
31	42252	1	O-ring
32	42253	1	O-ring
33	41359	1	Bol récupération clous
34	41360	1	Corp bol
35	43378	1	Embout
36	41729	1	Silencieux
37	41733	1	Fermeture
38	41730	1	Silencieux
39	41734	1	Bouchon
40	41443	1	Poignée gauche
41	41444	1	Poignée droite
42	41449	1	Levier
43	43382	1	Bouton levier
44	43383	1	Soupape
45	43384	6	O-ring
46	43385	6	Raccord
47	43386	6	Entretoise
48	43387	3	Tuyau air
49	43171	1	Embout
50	43172	1	Vis
51	43415	1	Soupape
52	43416	2	O-ring
53	41450	4	Vis
54A	43152	1	Corp soupape
55	41376	1	Bauge soupape

56	41377	2	O-ring
57	41378	1	Base soupape
58	43115	1	Raccord
59	42254	2	O-ring
60	43389	1	Raccord
61	42255	1	O-ring
62	42940	1	Raccord evoluabre
63A	41379	1	Tige soupape
64	43052	1	Vis
65	41731	1	Silenceur
66A	43393	1	Culot de protection
67	41380	1	O-ring
68A	43400	2	Vis
69	43402	1	Embout
70	41810	2	Ammortisseur
71	41381	1	O-ring
72	41382	1	Rondelle teflon
73	43404	1	Piston
74	42257	1	Rondelle
75	43418	1	Tuyau
76	43444	1	Tige
77	43406	1	Piston pneumatique
78	41385	1	O-ring
79	42654	1	Vis
80	41655	2	O-ring
81	43425	1	Cylindre
82	43173	1	Culot de protection
83	42396	1	Garniture
84	43174	1	Bouchon oil
85	43175	1	Crochet
86	41990	1	Embout Ø 2,4
87	41991	1	Embout Ø 3,0 - 3,2
88	41992	1	Embout Ø 4,0
89	40417	1	Embout Ø 6,0
90	41691	1	Embout Ø 4,8
91	25248	1	Embout Ø 4,8 3/16 pour rivets Monriv

Kit 503 - Kit bol récupération

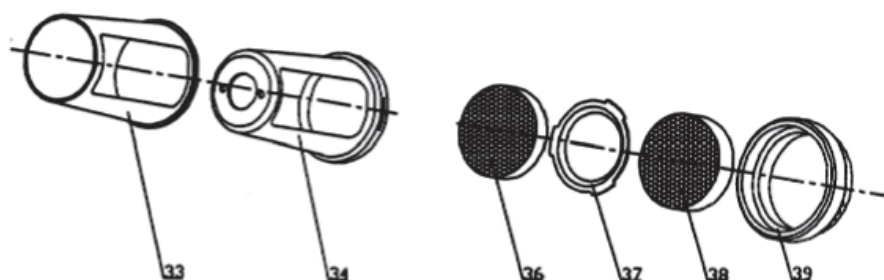

REF.	CODE	QUANTITE'	DESCRIPTION
	42042	1	Kit bol récupération

32	42253	1	O-ring
33	41359	1	Bol récupération
34	41360	1	Corp bol
36	41729	1	Silencieur
37	41733	1	Fermeture
38	41730	1	Silencieur
39	41734	1	Bouchon

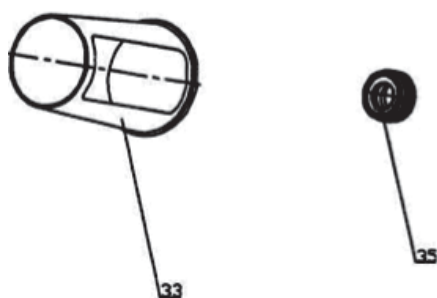

33	41359	1	Bol récupération
35	43378	1	Embout

Kit 503 - Kit piston pneumatique

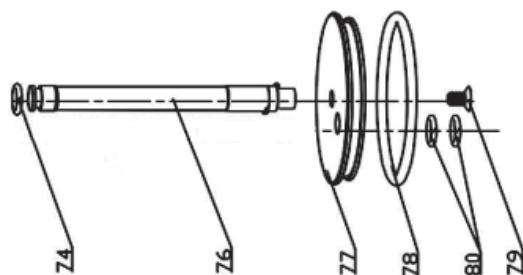

REF.	CODE	QUANTITE'	DESCRIPTION
-	43424	1	Kit piston pneumatique

74	42257	1	Rondelle
76	43444	1	Tige
77	43406	1	Piston pneumatique
78	41385	1	O-ring
79	42654	1	Vis
80	42655	2	O-ring

DICHIARAZIONE DI CONFORMITA'
DECLARATION OF CONFORMITY
DÉCLARATION DE CONFORMITÉ

DEGOMETAL

Z.I - 1 ère Avenue - 5 ème Rue - BP 443 - 06515 Carros Cedex 1 - France

DICHIARA - DECLARES - DECLARE

nella persona di: - in the person of: - en la personne de:
Benjamin Blincourt
(Supplying responsible)

sotto la propria esclusiva responsabilità che la Macchina
under our sole responsibility that the tool
sous la propre responsabilité exclusive que la machine

GO 580

N° Matricola | Serial N° | Numéro de pièce:

alla quale questa dichiarazione si riferisce è:
to which this declaration relates is:
à laquelle cette déclaration se réfère est:

CONFORME - IN CONFORMITY - CONFORME

alle disposizioni della Direttiva Macchine 2006/42/CE
with the provisions of the Machine Directive 2006/42/EC
aux dispositions des Directives Machines 2006/42/EC

Documentazione tecnica presso:
Technical documentation at:
La documentation technique:

Degometal

Z.I - 1 ère Avenue - 5 ème Rue - BP 443 - 06515 Carros Cedex 1 - France

Carros, le _____

Firma | Signature | Signature





Degometal

Z.I - 1 ère Avenue - 5 ème Rue - BP 443 - 06515 Carros Cedex 1 - France
Tél. +33 (0)4 92 08 56 56 Fax +33 (0)4 92 08 56 57 www.degometal.com